

# SECONOV 2500 | 3000 | 4000

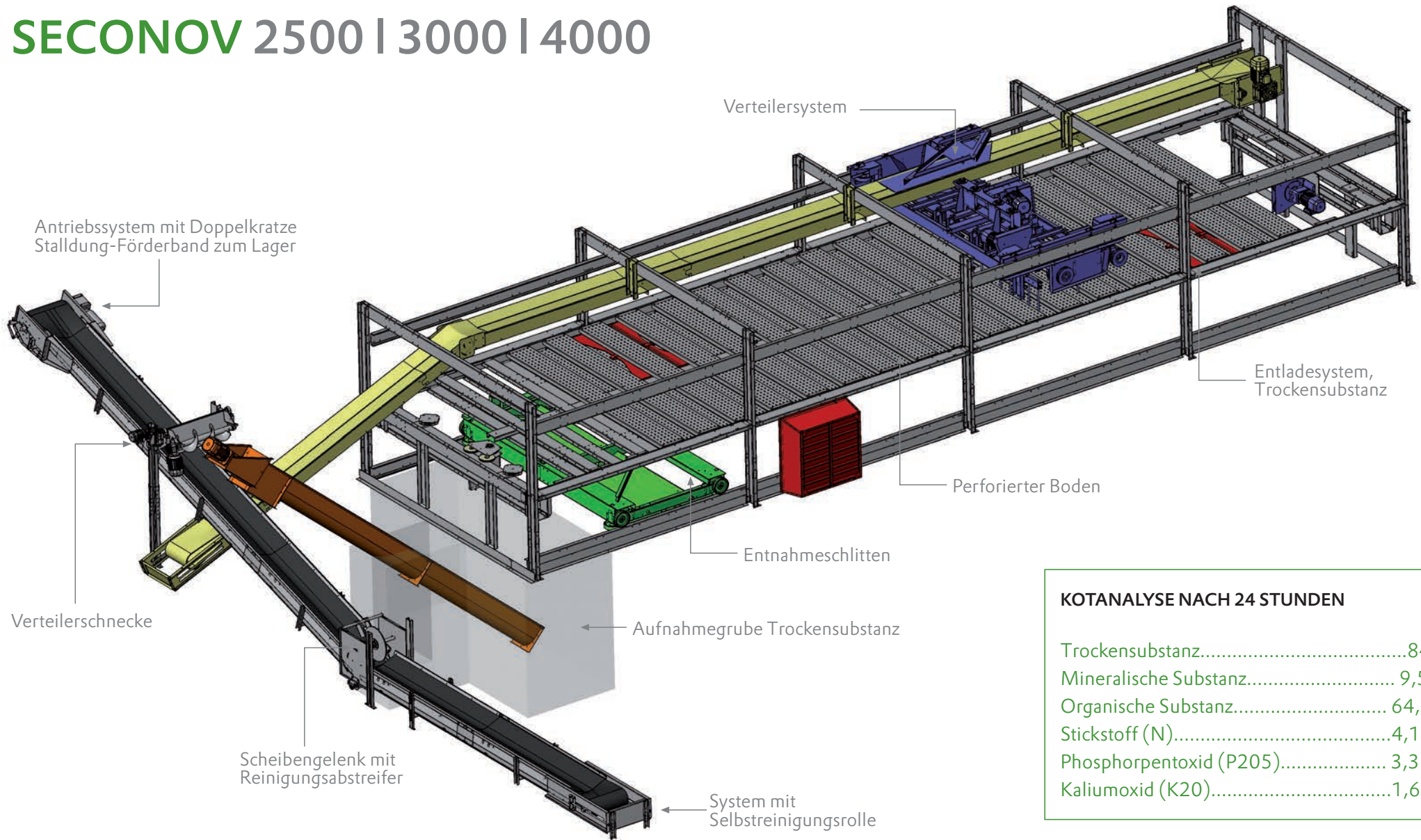

## KOTANALYSE NACH 24 STUNDEN

Trockensubstanz.....	84%
Mineralische Substanz.....	9,5%
Organische Substanz.....	64,7%
Stickstoff (N).....	4,10%
Phosphorpentoxid (P205).....	3,35%
Kaliumoxid (K20).....	1,62%



**zucami**<sup>®</sup>  
POULTRY EQUIPMENT

Polígono Morea Norte, calle C - Nº 2 | 31191 Beriain, Navarra, SPAIN  
 T +34 948 368 301 | F +34 948 368 363  
 www.zucami.com

*The green ones*

# KAPAZITÄT 200.000 TIERE

## HÜHNERMIST-LAGERHALLE

Getrocknet  
in 24 Stunden  
Trockensubstanz  
80/85%

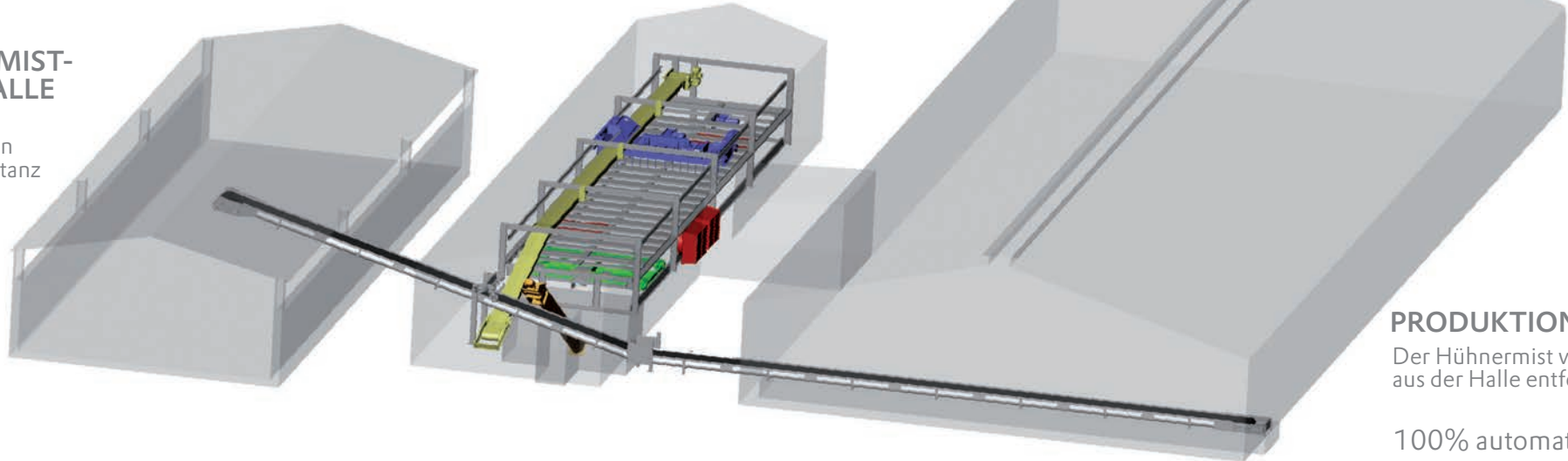

## PRODUKTIONSHALLE

Der Hühnermist wird täglich  
aus der Halle entfernt.

100% automatischer Prozess

Darstellung der gestaltung einer hühnermist-trockenanlage **SECONOV 4000**

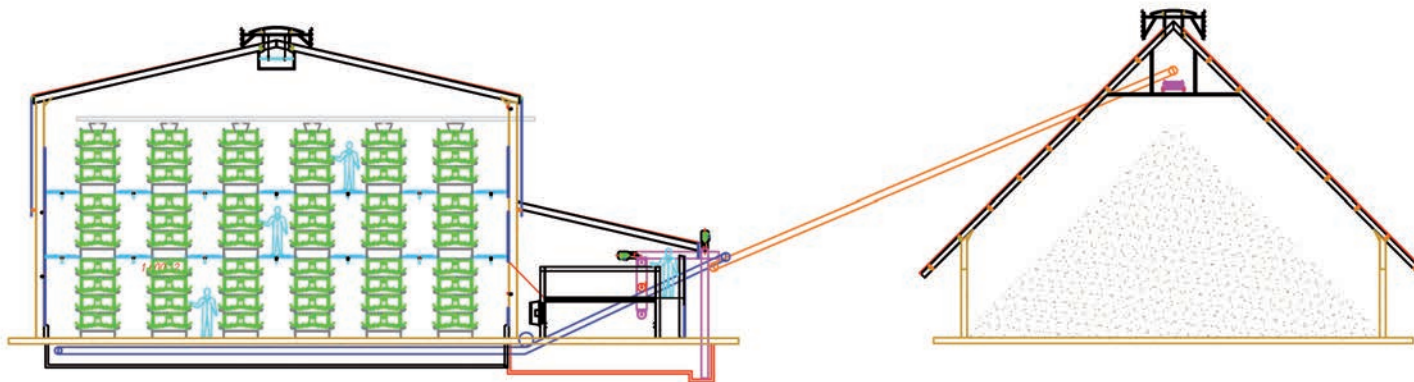

**zucami**<sup>®</sup>  
POULTRY EQUIPMENT

Polígono Morea Norte, calle C - Nº 2 | 31191 Beriain, Navarra, SPAIN

T +34 948 368 301 | F +34 948 368 363

[www.zucami.com](http://www.zucami.com)

*The green ones*

