

# SECONOV 2500 | 3000 | 4000

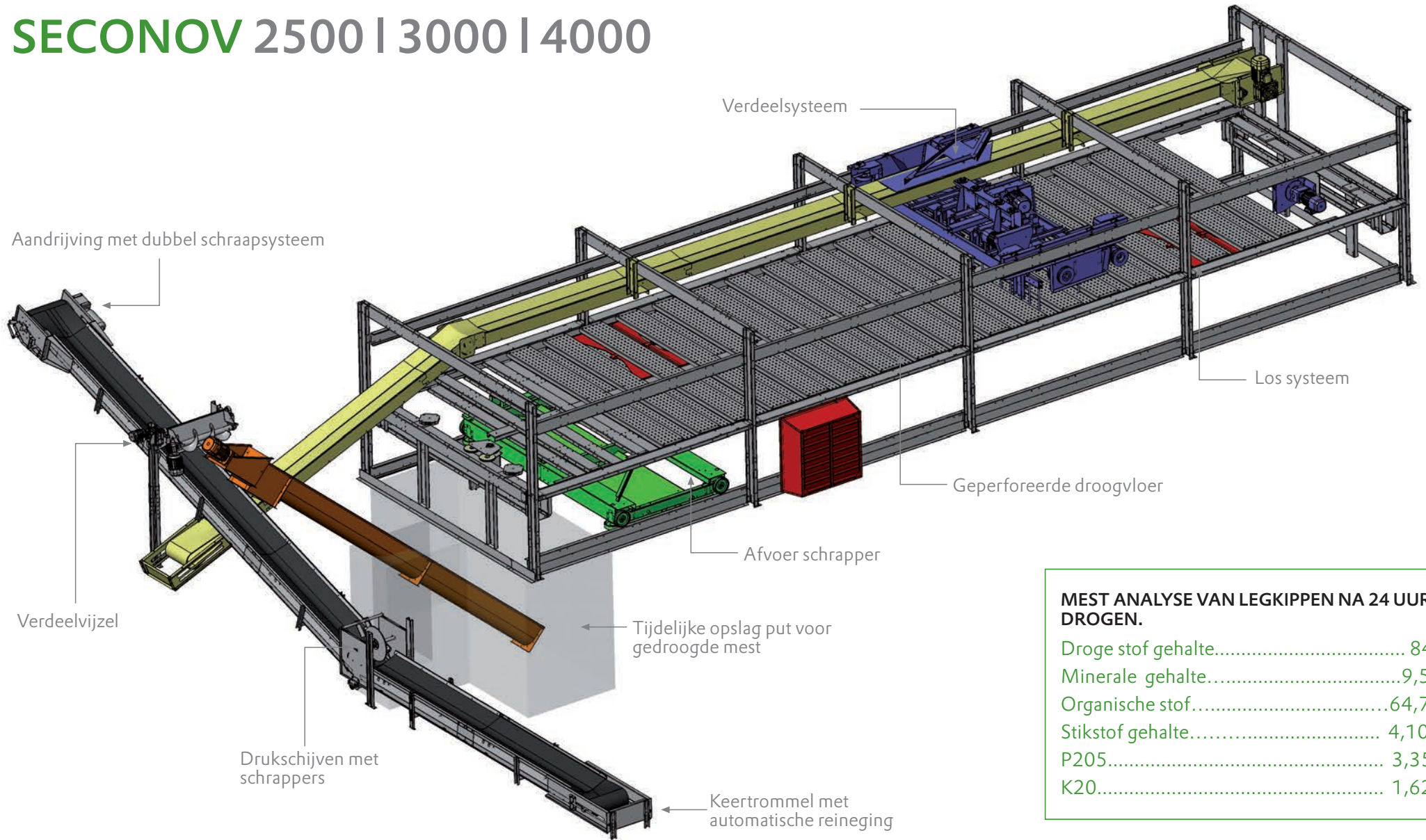

**MEST ANALYSE VAN LEGKIPPEN NA 24 UUR DROGEN.**

Droge stof gehalte.....	84%
Minerale gehalte.....	9,5%
Organische stof.....	64,7%
Stikstof gehalte.....	4,10%
P205.....	3,35%
K20.....	1,62%



**zucami**<sup>®</sup>  
POULTRY EQUIPMENT

Polígono Morea Norte, calle C - Nº2 | 31191 Beriain, Navarra, ESPAGNE  
 T +34 948 368 301 | F +34 948 368 363  
 www.zucami.com

*The green ones*

# CAPACITEIT 200.000 LEGKIPPEN

## MEST OPSLAG

Gedroogd op 24 uur  
80/85 %  
droge stof

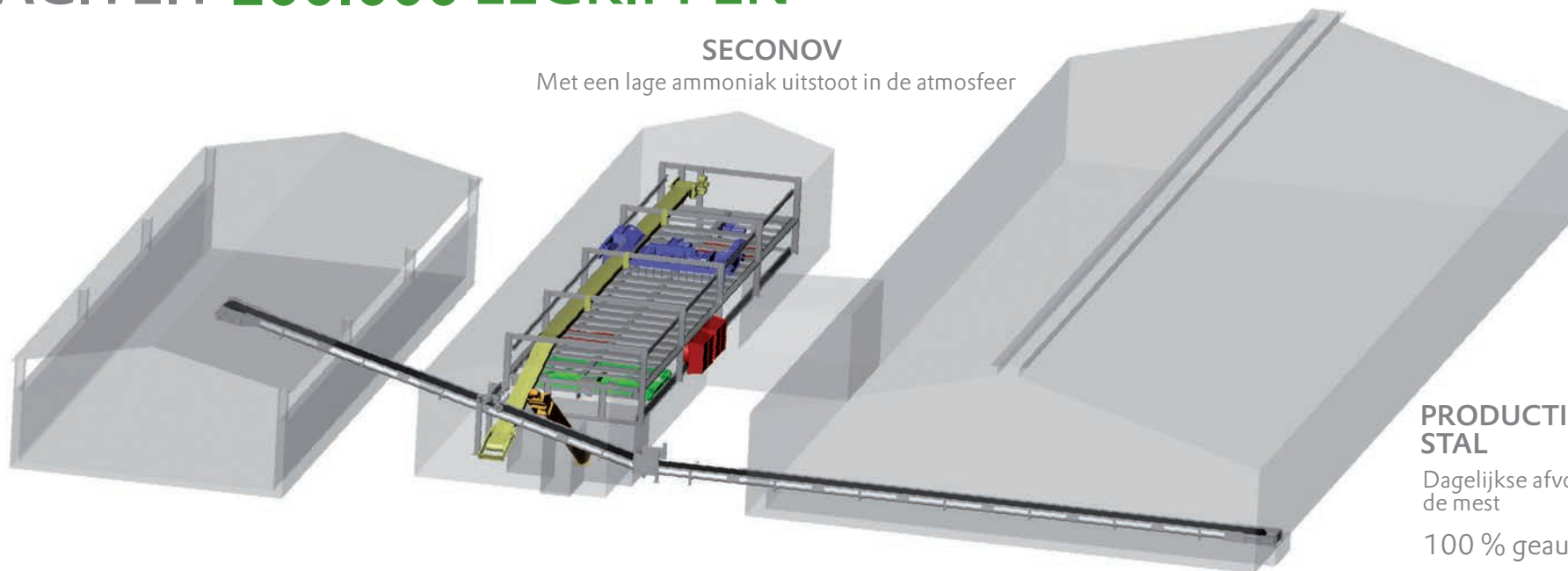

## SECONOV

Met een lage ammoniak uitstoot in de atmosfeer

## PRODUCTIE STAL

Dagelijkse afvoer van de mest

100 % geautomatiseert

Presentatie van een mest droog installatie **SECONOV 4000**

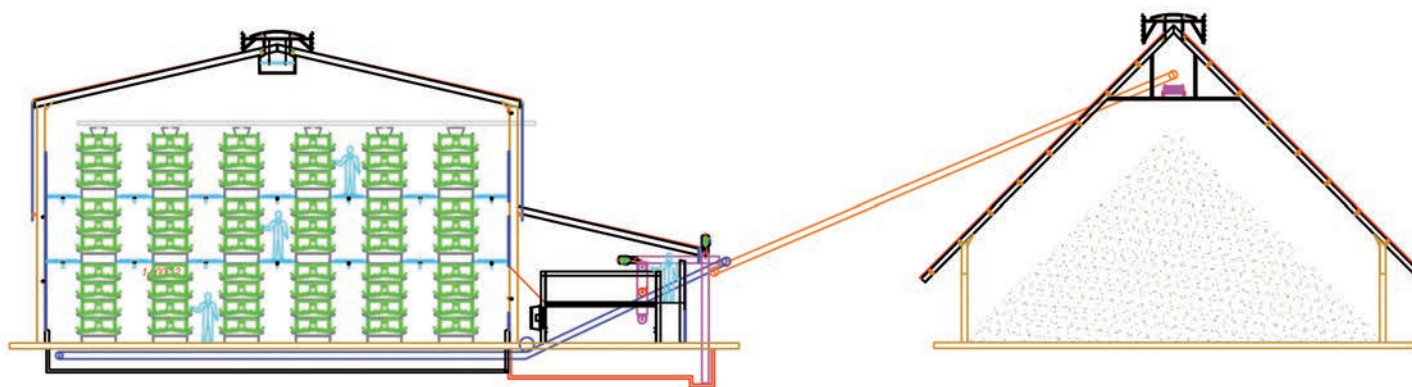

**zucami**<sup>®</sup>  
POULTRY EQUIPMENT

Polígono Morea Norte, calle C - Nº2 | 31191 Beriain, Navarra, ESPAGNE

T +34 948 368 301 | F +34 948 368 363

www.zucami.com

*The green ones*

